

# GH Series Gage Head LVDT



This linear bearing spring loaded Gage Head is specially designed for heavy duty high resolution position measurements. Hardened Steel contact tip can be removed and replaced if damaged. Steel casing serves for electromagnetic and electrostatic shielding. The Gage Head contains an AC LVDT and it needs a signal conditioner electronics to operate, such as digital or analog EL-35 signal conditioners, USB-10 or USB-10-4 digital controllers. All are manufactured by Singer Instruments & Control.

## Specifications

<b>Input voltage</b> . . . . .	3V rms (nominal)
<b>Input Frequency</b> . . . . .	50 to 10000 Hz range, 5kHz nominal
<b>Linearity deviation error</b>	0.25% of full range output
<b>Operating temperature range</b> . . . . .	-20°C to 70°C
<b>Housing material</b> . . . . .	Chrome plated High carbon steel
<b>Lead wires</b> . . . . .	Shielded 4 or 5 Lead Cable 500 mm long
<b>Contact tip</b> . . . . .	Hardened steel ball, 3 mm diameter



## Dimensions (mm)

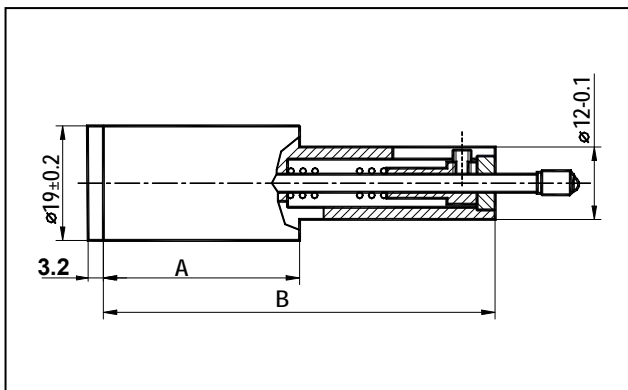

## Wiring

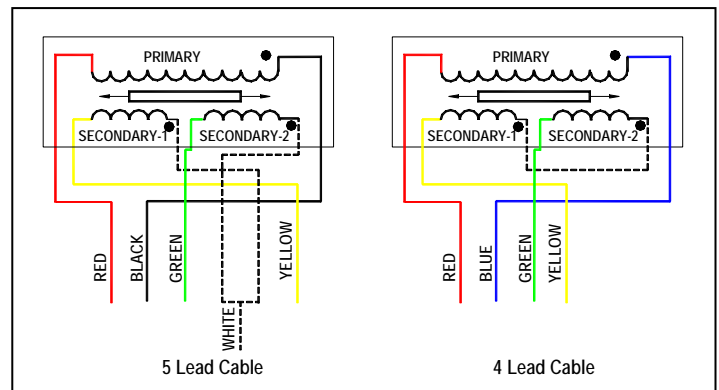

## How to order

Ordering example: Model number – GH- 1.5 4 leads.

TYPE	Linear Measuring Range mm	Moving Range, min mm	Measuring Force * gr	Sensitivity (tested at 5kHz) V/mm/Vex	Repeatability µm	Impedance (tested at 5kHz)		Resistance		Length	
						Ω		Ω		mm	
						Prim.	Sec.	Prim.	Sec.	A	B
<b>GH-1.5</b>	±1.5	3.5	40-60	0.13	±0.1	220	720	60	170	34.5±0.3	69.5±0.5
<b>GH-3</b>	±3	6.5	40-70	0.11	±0.1	310	1200	95	270	49.5±0.3	83.5±0.5
<b>GH-5</b>	±5	10.5	40-105	0.06	±0.15	420	1300	110	260	78±0.3	113±0.7
<b>GH-10</b>	±10	21	55-115	0.04	±0.15	440	1500	90	210	104±0.3	149±0.7

\* Max deviation ±20%

Rev. G

© Singer Instruments & Control Ltd., 2009

WWW.SINGER-INSTRUMENTS.COM

Information furnished by Singer Instruments & Control is believed to be accurate and reliable. However, no responsibility is assumed by Singer Instruments & Control for its use, nor for any infringements of patents or other rights of third parties which may result from its use. No license is granted by implication or otherwise under any patent or patent rights of Singer Instruments & Control Ltd.

## Singer Instruments & Control Ltd.

2 Yozma St., Tirat Carmel 39032, ISRAEL  
yuval@singer-instruments.com

540 East Main St., Branford, CT 06405, USA  
fred@singer-instruments.com

Tel: 972-4-857-8880  
Fax: 972-4-857-8881

Tel: 203-481-7278  
Fax: 203-488-7190