

Tension-Compression Load-Cell, LC-AC Series



The LC series force transducer is an LVDT type, featuring practically unlimited life time, making it suitable for fast automatic weighing machines. Internal springs construction include damping properties, thus limiting overshoot, and shortening the response time.

This Load-Cell contains an AC LVDT and therefore requires a signal conditioner electronics to operate, if such as digital or analog EL-35 signal conditioners and USB-10 or USB-10-4 digital controllers. All are manufactured by Singer Instruments & Control.

Specifications:

Measuring range	1 Kg. (LC-1AC); 2 Kg. (LC-2AC); 5 Kg. (LC-5AC); 10 Kg. (LC-10AC);
Measuring frequency	DC to 20 Hz
Linearity error	0.15% F. S.
Hysteresis error	0.02% F. S.
Input voltage	3V rms (nominal)
Input Frequency	6kHz (nominal)
Output	150 to 300 mV rms F. S.
Deflection	0.1 mm typ.
Overload capability	200% to 1000%, depending on range
Side load capability	100% typ.
T.C. of sensitivity	0.01% / °C typ.
T.C. of zero	0.01% FS / °C typ.
Operating temperature range	-20°C to + 70°C
Resistance:	
Prim.	190 Ω
Sec.	190 Ω
Impedance:	
Prim.	250 Ω
Sec.	350 Ω
Shock Survival	500g for 11 msec
Vibration Survival	20 g up to 500 Hz
Lead wires	Shielded 6 wire Cable 500 mm long
Housing material	Anodized Aluminum alloy
Weight	550 grams



How to order

Ordering example:
Model number: LC – 1AC. (for measuring range 1kg)

Dimensions (mm):

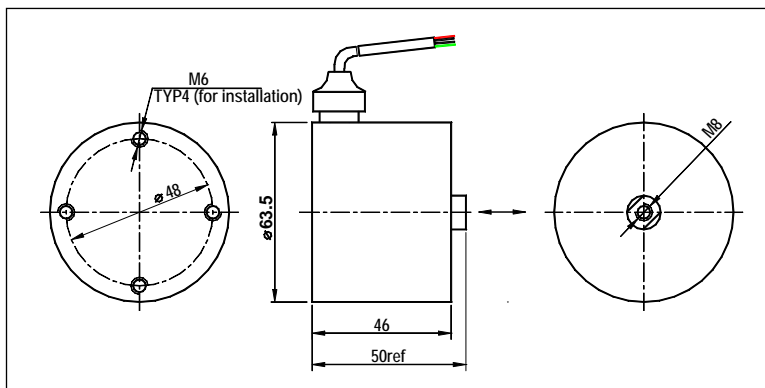

Wiring

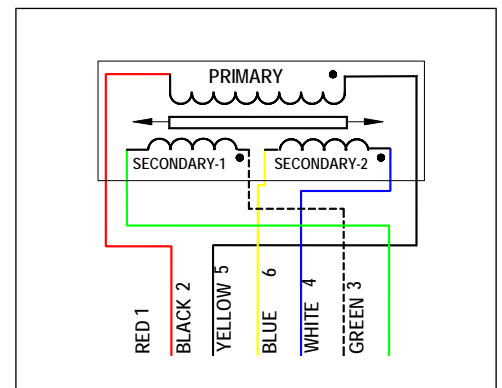

Rev. G

© Singer Instruments & Control Ltd., 2009

WWW.SINGER-INSTRUMENTS.COM

Information furnished by Singer Instruments & Control is believed to be accurate and reliable. However, no responsibility is assumed by Singer Instruments & Control for its use, nor for any infringements of patents or other rights of third parties which may result from its use. No license is granted by implication or otherwise under any patent or patent rights of Singer Instruments & Control Ltd.

Singer Instruments & Control Ltd.

2 Yozma St., Tirat Carmel 39032, ISRAEL
yuval@singer-instruments.com

Tel: 972-4-857-8880
Fax: 972-4-857-8881

540 East Main St., Branford, CT 06405, USA
fred@singer-instruments.com

Tel: 203-481-7278
Fax: 203-488-7190