

DC INPUT / DC OUTPUT DISPLACEMENT TRANSDUCERS S-D AND M-D SERIES

The Instruments & Control S-D and M-D series are displacement transducers of LVDT type with self-contained signal conditioners. Their output is a DC voltage proportional to the displacement of the core from its zero position, while the polarity indicates the direction of the displacement.

Some of their features:

- High linearity and stability.
- Negligible sensitivity to supply voltage fluctuation.
- Low output impedance to minimize loading effects.
- Protection against supply polarity reversing.
- Low power consumption, 200 mW typical.
- Infinite resolution: dynamic ranges of better than 100,000:1 are practical.
- All-metal design, including the coil form, for ruggedness and dimensional stability.



SPECIFICATIONS	S-D Series	M-D Series
Linearity	0.25%FR typ ¹⁾	0.15%FR typ.
Input	±15V nominal, 13.5 to 16.5V range, 8 mA typ.	
Output	±5 VDC F.S.	
Output impedance	Less than 10 Ω	
Minimum load resistance	100 Ω	
T. C. of zero	0.01% F.R./°C typ. (0° to 70°C)	
T. C. of scale factor	0.03% /°C typ. (0° to 70°C)	
Operating temperature range	-25°C to 85°C	
Survival temperature range	-55°C to 95°C	
Frequency response	0 to 100 Hz, ±3 db	
Ripple	Less than 0.25% F.S., 5KHz typ.	
Shock survival	250g, 11ms	
Vibration	20g, up to 2 KHz	
Housing material	400 series Stainless Steel	300 series Stainless Steel
Lead wires	#28 AWG plated, stranded copper, Teflon insulated, 12" long (300 mm)	

1) For model S10, the linearity is 0.5%F.R.

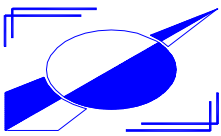

BLOCK DIAGRAM OF S-D AND M-D LVDT'S

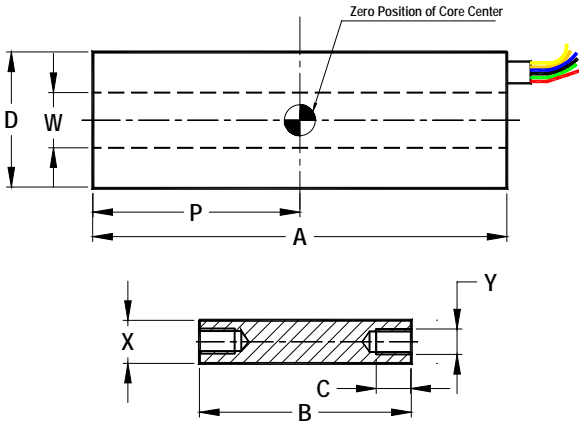
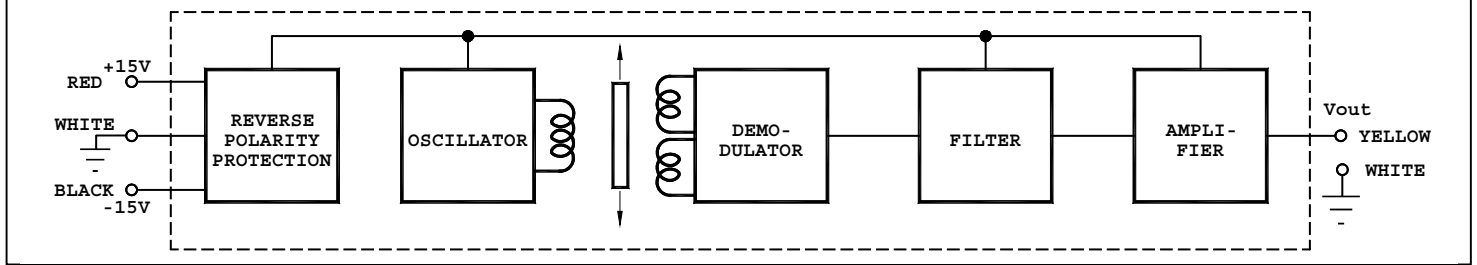

NOTE: Output will be positive when core moves from zero toward lead wires end of LVDT

	S-D Series		M-D Series	
	inches	mm	inches	mm
D	0.750(+0.008, -0.004)	19(+0.20, -0.10)	0.750±0.005	19±0.13
W	0.303±0.008	7.7±0.2	0.148±0.004	3.75±0.10
X	0.235±0.005	6.0±0.10	0.110±0.005	2.8±0.10
Y	#4-40 UNF-2B	M3x0.5-6H	#1-72 UNF-2B	M2x0.4-6H
C	0.4min	10 min	0.3min	7.5min

S – D Series:

MODEL	LINEAR RANGE		DIMENSIONS						CORE WEIGHT Grams
			A		B		P		
	inches	mm	inches	mm	inches	mm	inches	mm	
S.1 D	±0.100	±2.5	2.40	61	0.80	20	0.60	15	4
S.2 D	±0.200	±5.0	3.60	91	1.71	43	1.20	30.5	8
S.5 D	±0.500	±12.5	5.50	140	3.0	76	2.15	55	14
S1 D	±1.000	±25.0	6.70	170	3.3	84	2.75	70	16
S2 D	±2.000	±50.0	12.00	305	6.45	164	5.40	137	30
S5 D	±5.000	±125.0	23.70	602	11.60	295	11.25	286	55
S10 D	±10.000	±250.0	37.20	945	22.0	559	18.00	457	104

M – D Series:

M.02 D	±0.020	±0.5	0.95	24.1	0.375	9.5	A/2	0.3
M.05 D	±0.050	±1.25	0.95	24.1	0.575	14.6	A/2	0.5
M.1 D	±0.100	±2.5	1.20	30.5	0.720	18.3	A/2	0.7
M.2 D	±0.200	±5.0	2.10	53.3	1.425	36.2	A/2	1.3
M.5 D	±0.500	±12.5	3.50	88.9	1.830	46.5	A/2	1.7
M1 D	±1.000	±25.0	5.00	127	2.700	68.6	A/2	2.5

All specifications subject to change without notice.

Instruments & Control Inc.

Information furnished by Instruments & Control is believed to be accurate and reliable. However, no responsibility is assumed by Instruments & Control for its use, nor for any infringements of patents or other rights of third parties which may result from its use. No license is granted by implication or otherwise under any patent or patent rights of Instruments & Control Inc.

540 East Main st., Branford, CT 06405, USA
fred@singer-instruments.com

Tel: 203-481-7278
Fax: 203-488-7190