

Dual-Axis Servo-Inclinometer, TSD series

This is two-axes inclinometer built of two TS inclinometers packaged in a single housing. As such, it features the same high performance resulting from closed – loop operation: high linearity, and virtually infinite resolution, low temperature sensitivity, repeatability, etc.

• SPECIFICATIONS:

Measuring range	$\pm 5^\circ$ to $\pm 90^\circ$
Supply voltage	$\pm 15V @ 10mA$
Full Scale output	$\pm 5V \pm 0.25\%$
Non-linearity error	0.01%FR typ
Bias	0.1% FR typ
Single axis misalignment	0.5° typ
Misalignment between axes	0.5° typ
Temp. coefficient of Zero	2 arc-sec /°C typ
Temp. coefficient of Scale	0.01%/°C typ
Temp. range, operating (storage)	-30 to +70°C (-40 to +85°C)
Constant acceleration	50g
Shock	250g, 11ms
Housing material	Anodized # 2024 Aluminum alloy



• OPERATION PRINCIPLE

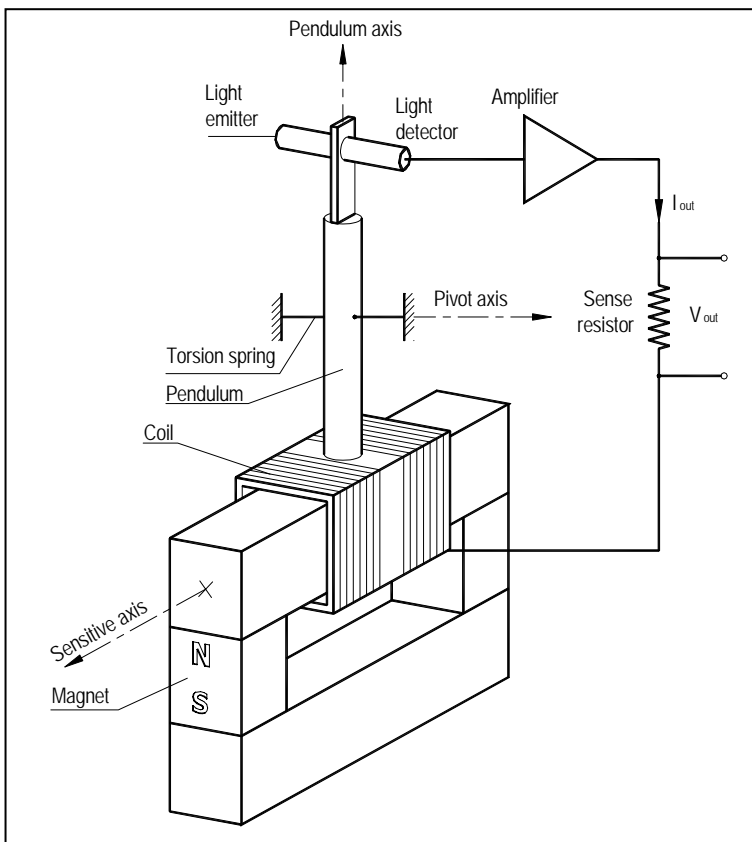

A pendulum is suspended from a low stiffness torsion spring. Pendulum rotation can be induced by a linear acceleration along its sensitive axis (acceleration mode), or by a component of the gravity force along that axis caused by tilt (tilt mode). The pendulum displacement is sensed by a photo – electric position sensor, the output of which is amplified and fed to the coil of an electromagnetic torquer attached to the pendulum. The polarity of the connection is chosen to produce a reaction torque which tends to return the pendulum to its zero position (negative feed – back). Since the input and reaction torque's exactly balance each other, the current producing the reaction torque is a very accurate and linear function of the acceleration and is used as output. In the tilt measuring mode, the output is proportional to the sine of the angle of tilt. This fact limits the effectivity of the sensor for tilt angles approaching $\pm 90^\circ$.

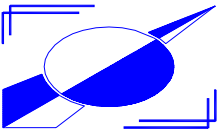

• DIMENSIONS (mm):

