

TORQUE TRANSDUCERS, MODELS T AND TD

Those are high accuracy reaction torque transducers, featuring low linearity and hysteresis errors, stable high level voltage output, fast response and ruggedness.

The measured torque applied to the input shaft produces a minute angular deflection of a torsion rod, which is detected by high sensitivity differential transformer. The AC version requires an AC supply and produces an amplitude modulated AC output. In the DC version, the internal signal conditioner requires an unregulated DC voltage supply, and produces an high level DC voltage output, which is practically not affected by load impedance.

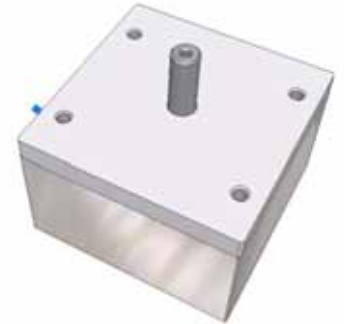

SPECIFICATIONS	MODEL TD	MODEL T
Ranges	±1, ±5, ±10, ±50 & ±100 Kg-cm F.R.	
Input	±15VDC ±10%, 20mA	6Vrms, 5KHz
Output, full scale	±1 to ±5 VDC	40mV/Vex
Output impedance	10 Ω	1.5 kΩ
Non-linearity *	0.1% F.R. typ.	
Non-repeatability & hysteresis	0.1% F.R. typ.	
Angular shaft deflection	±0.5° FR	
Overload capability	200%	
Sideload capability	100%	
Temperature range	-30 to +90°C	
T.C. of zero	0.02%FR/°C typ.	
T.C. of span	0.03% /°C typ	

* Non-linearity error defined as maximum deviation of any point from the best straight line between the points.

ORDERING INFORMATION:

For Model T specify measuring range, e. g.: T5 for a ±5 Kg-cm AC unit.

For Model TD specify range and output, e. g.: T50D5 for a ±50 Kg-cm DC unit with ±5 VDC full scale output. If not specified, full scale output will be ±2 VDC

• DIMENSIONS (INCH/[mm]):

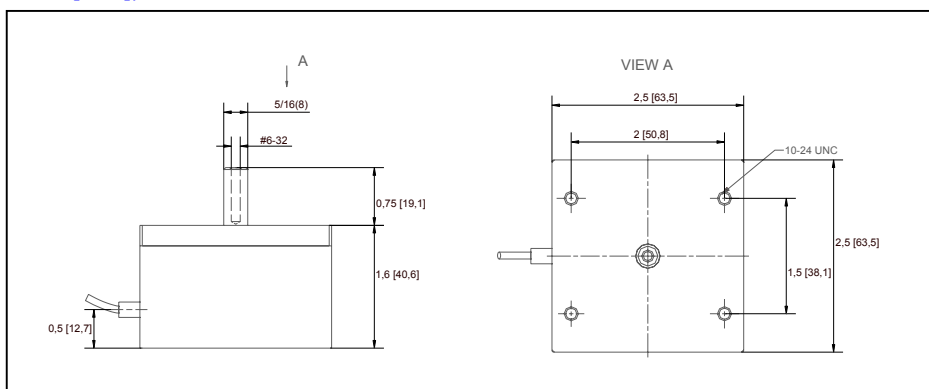

Housing material: Clear anodized # 2024 Aluminum alloy.

Rev. A

© Instruments & Control Inc., 2004

WWW.SINGER-INSTRUMENTS.COM

Information furnished by Instruments & Control is believed to be accurate and reliable. However, no responsibility is assumed by Instruments & Control for its use, nor for any infringements of patents or other rights of third parties which may result from its use. No license is granted by implication or otherwise under any patent or patent rights of Instruments & Control Inc.

Instruments & Control Inc.

540 East Main st., Branford, CT 06405, USA
fred@singer-instruments.com

Tel: 203-481-7278
Fax: 203-488-7190